



# Cable Top Sailcloth Replay Top with Tinted Windows

## Installation Instructions

For: Jeep Wrangler (JK) 2 Door  
2010 and Newer  
**Part Number: 51203**



### Installation Tips

Before you begin installing this assembly, read all instructions thoroughly.

#### For a smooth fit:

For ease in installation, the product should be installed at temperatures above 72° F. Below this temperature, the fabric may contract an inch or more, making it difficult to fit to the vehicle. It is normal for fabric to contract and wrinkle when stored in the shipping carton. Within a few days after the installation, the fabric will relax and the wrinkles will disappear.



## WARNING

This product is designed to enhance the appearance of the vehicle. Do not rely in any way on the components of this product to contain occupants within the vehicle, or to protect against injury or death in the event of an accident. Never operate vehicle in excess of manufacturer's specifications.

### WEAR SEAT BELTS AT ALL TIMES

Read and follow, precisely, all installation instructions provided when installing this product. Failure to do so could place occupants of the vehicle in a potentially dangerous situation. After installing or reinstalling, check to make sure it has been properly installed.

## Table of Contents

WRANGLER REPLAY TOP PARTS LIST .....	PAGE 2
WRANGLER REPLAY TOP TOOLS NEEDED .....	PAGE 2
WRANGLER REPLAY TOP INSTALLATION .....	PAGE 2
WRANGLER REPLAY TOP WARRANTY .....	PAGE 9



## CAUTION

Safety glasses should be worn at all times while installing this product.

## Tools Needed

Safety Glasses  
Phillips Screwdriver  
Masking Tape  
Pliers  
T-15 Torx Wrench

## Parts List

Fabric Top	Qty - 1
Quarter Window, Right	Qty - 1
Quarter Window, Left	Qty - 1
Rear Window	Qty - 1
Elastic Garter	Qty - 2
Header Foam, Driver's Side	Qty - 1
Header Foam, Passenger Side	Qty - 1
Fabric Foam	Qty - 2

### Step One

#### REMOVE QUARTER WINDOWS AND REAR WINDOW

Remove the Quarter Windows and the Rear Window. Remove the metal Tailgate Bar from the bottom of the Rear Window and set it aside.

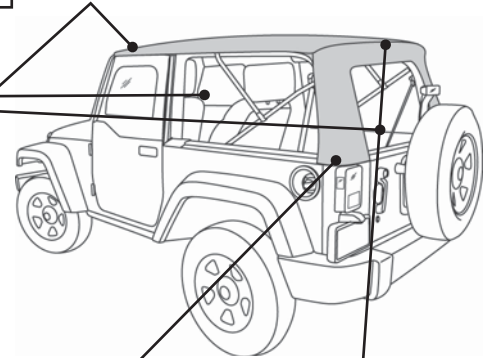

### Step Two

#### RELEASE WINDSHIELD LATCHES

Release the latch that secures the header to the windshield. Pull up on the lever and then down and out to release the hook from the loop in the windshield frame.

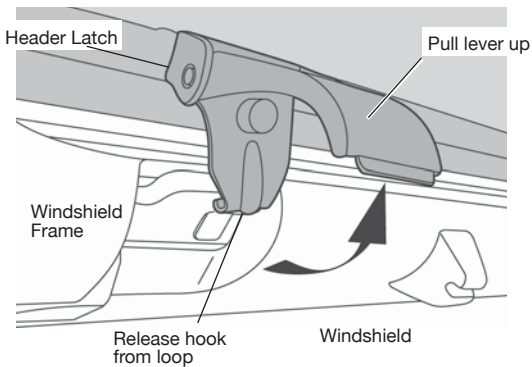

### Step Four

#### RELEASE REAR BOW

Use a phillips screwdriver to remove the four (4) screws that attach the flap in the top to the rear bow. Set the screws aside to be reused later. Allow the bow to drop onto the tailgate.

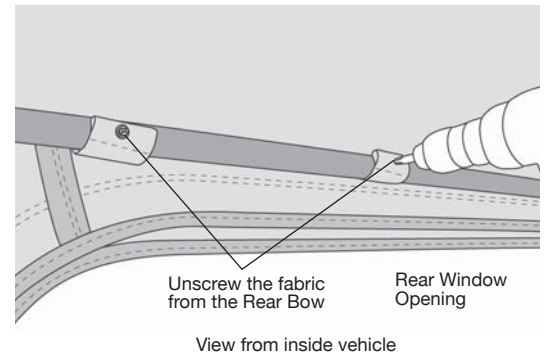

### Step Three

#### RELEASE REAR CORNERS

Release the rear corners of the top. Pull gently down and then out to release the plastic strip from the retainer on the vehicle.

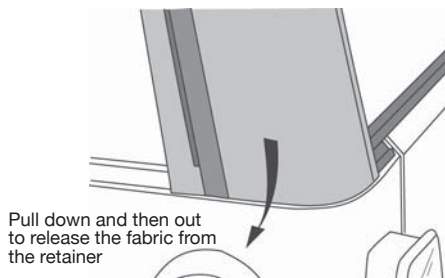

## Step Five

### UNFASTEN CENTER BOW

Use a phillips screwdriver to remove the five (5) screws that attach the flap in the top to the Center Bow. Set the screws aside to be reused later.

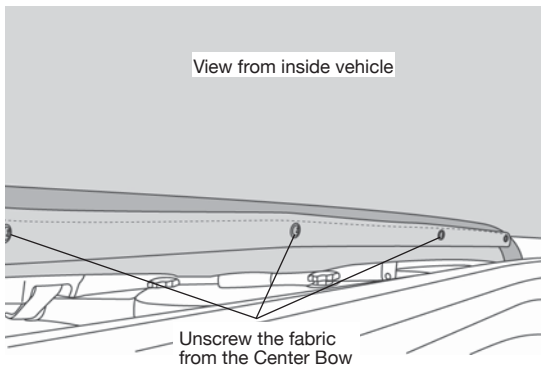

## Step Six

### REMOVE HEADER SCREWS

Collapse the bow assembly down onto the tailgate to access the header. Use a T-15 Torx to remove the two screws that secure the fabric to the header.

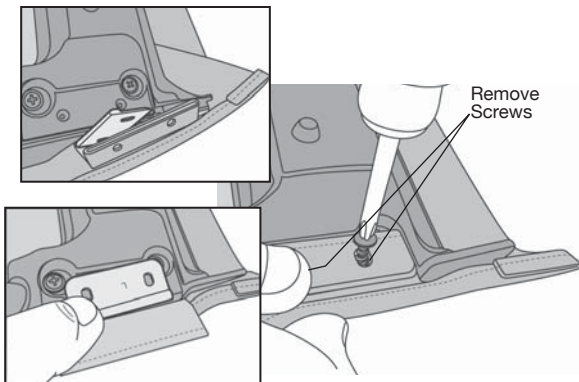

## Step Seven

### REMOVE TOP FABRIC

Raise the bow assembly and lock the header to the windshield. Drape the top fabric, backing side up, over the hood and windshield. Remove the twenty-seven (27) screws that secure the fabric to the upper and lower headers. Set the screws aside for use in installing the new top. Slide the extrusion along the front edge of the top out of the channel in the lower header and remove the old top from the vehicle.

Top Fabric - Backing Side Up

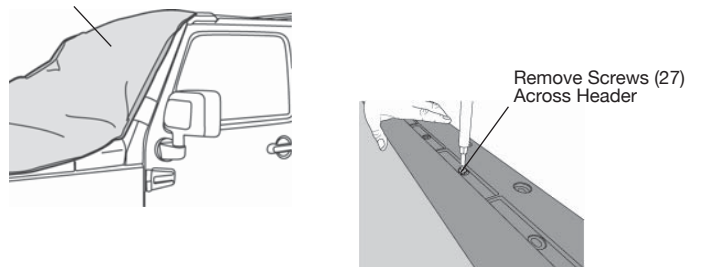

Slide Extrusion along the Front Edge of the Channel to remove Top

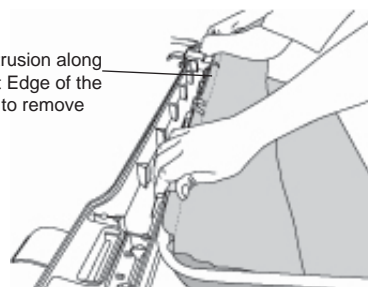

## Step Eight

### INSTALL TOP FABRIC

Raise the bow assembly and lock the header to the windshield.

Drape the top fabric, backing side up, over the hood and windshield. Slide the extrusion along the front edge of the top into the channel in the lower header. Line up the center drill hole in the fabric with the center notch in the header. Use masking tape to help hold the fabric in place along the lower header.

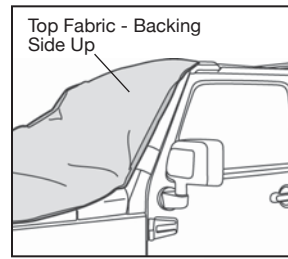
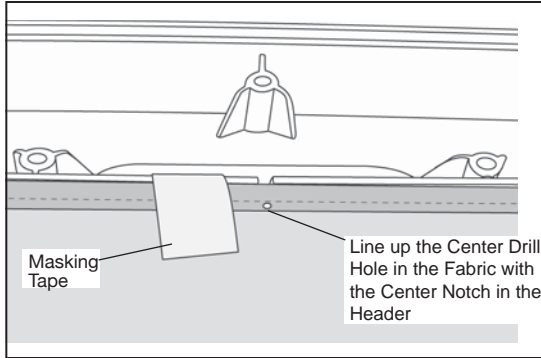

Slide Extrusion along the Front Edge of the Channel

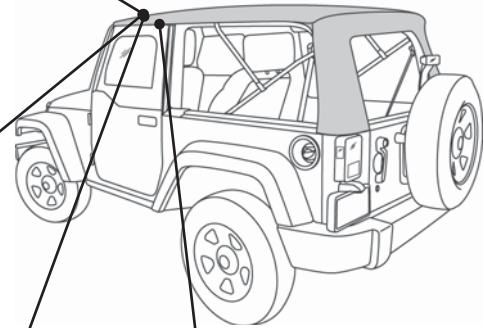
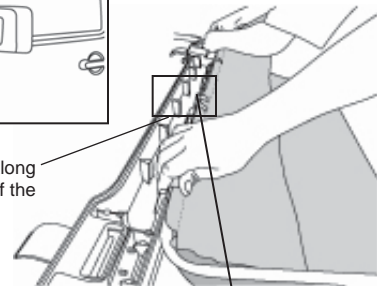

## Step Nine

### INSTALL TOP FABRIC

Close the upper header over the fabric, sandwiching the fabric. Reinstall the four (4) corner screws. Then install the twenty-three (23) screws across the header.

Lower the bow assembly to the rear of the vehicle.

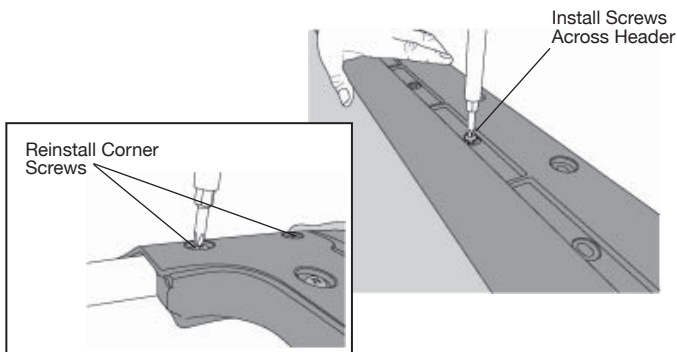

## Step Ten

### INSTALL CORNER SCREWS

Slip the fabric pocket sewn into the top between the headers and position the cable anchor.

Install two (2) T-15 Torx Screws through the fabric and metal flag into the Lower Header on each side.

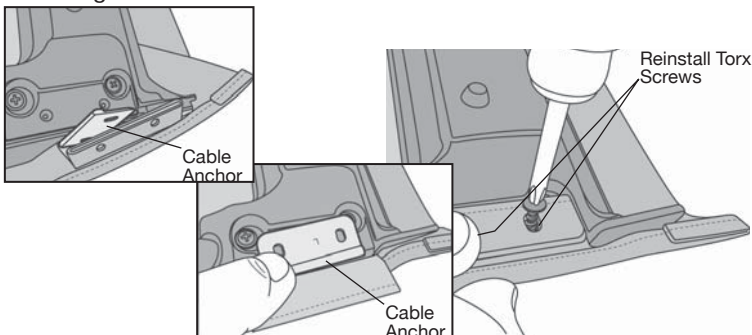

## Step Eleven

### SECURE CABLE SPRING

Hook the Cable Spring to the bracket on the bow and use pliers to crimp the spring.

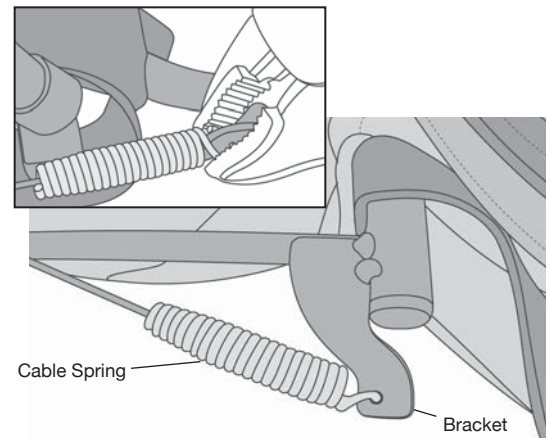

## Step Twelve

### INSTALL FABRIC FOAM

Peel the backing off the Fabric Foam and install it on each side of the Header.

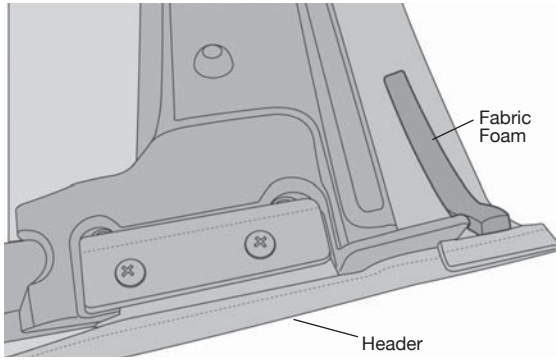

## Step Thirteen

### INSTALL HEADER FOAM

Peel the backing off the Driver's Side Header Foam and install it on the driver's side of the Header. Repeat on the passenger side.

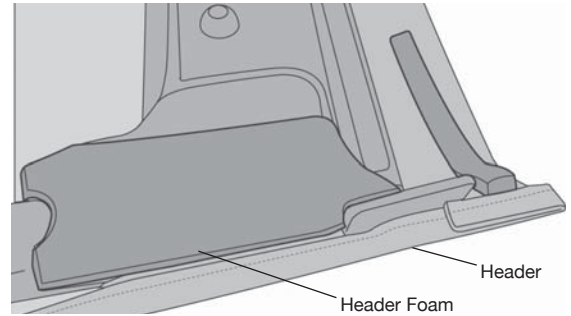

## Step Fourteen

### DRAPE TOP OVER CAB

Open the top and drape the fabric over the cab.

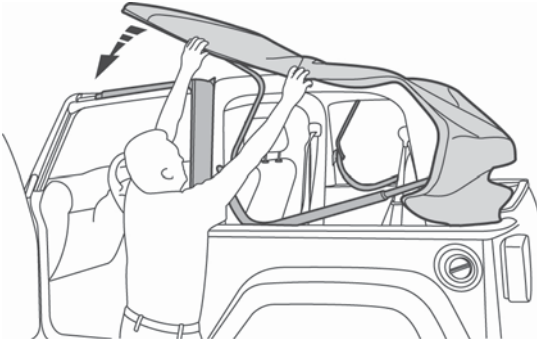

## Step Fifteen

### ATTACH TOP TO REAR BOW

Locate the flaps inside the top above the rear window opening. Use the four (4) screws that were removed in Step 4 to secure the flaps to the Rear Bow.

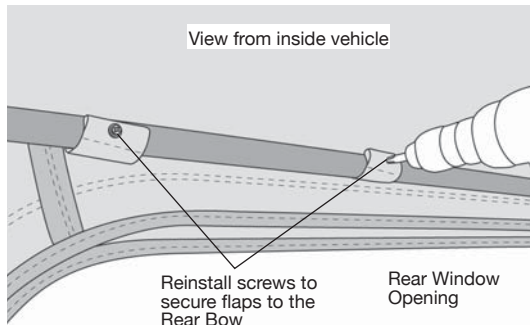

## Step Sixteen

### SECURE CENTER BOW

Reinstall the screws removed in Step 5 to secure the fabric to the Center Bow.

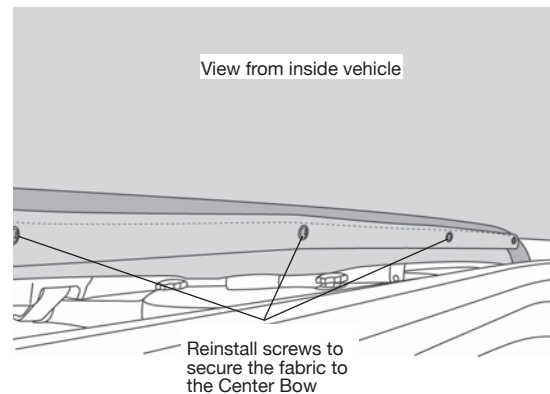

## Step Seventeen

### SECURE HEADER TO WINDSHIELD

Close the header latches to secure the front of the top to the windshield. Catch the hook in the loop in the windshield frame and then close the lever over it so that it lays flat against the windshield frame.

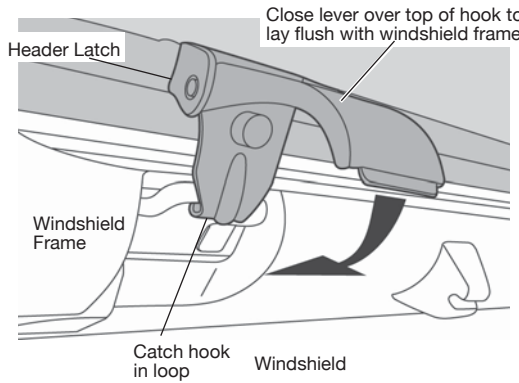

## Step Nineteen

### ATTACH QUARTER WINDOW ZIPPERS

Start the zipper on the Quarter Window and close it 1-2 inches.

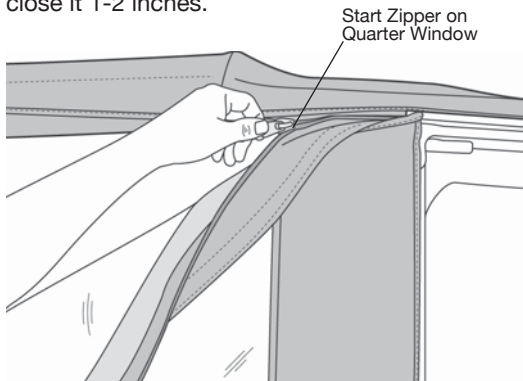

## Step Twenty

### SECURE FRONT OF QUARTER WINDOW

Roll the plastic strip along the front of the Quarter Window into the channel in the Door Surround.

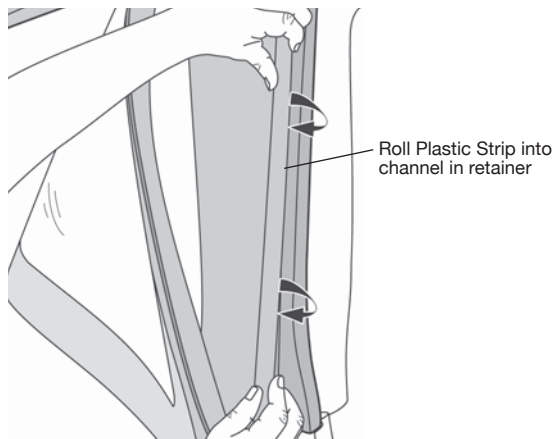

## Step Eighteen

### SECURE REAR CORNERS

Pull down gently on the Rear Bow and work the plastic sewn to the rear corners of the top into the retainer on the vehicle.

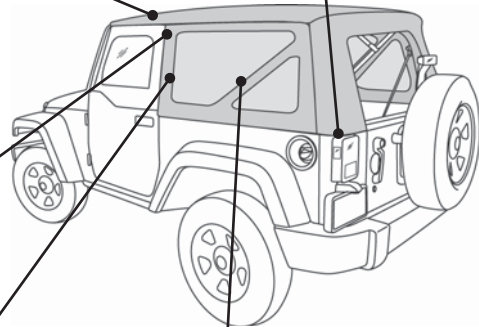
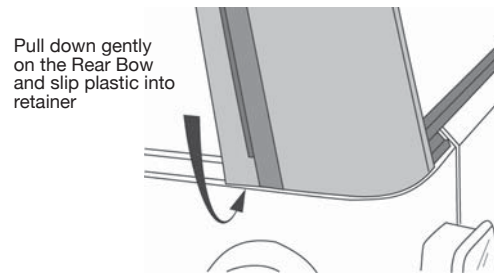

## Step Twenty-one

### SECURE QUARTER WINDOW

Close the zipper and slip the plastic along the bottom of the Side Window into the channel on the vehicle.

Fasten the hook and loop strip above the window to the top.

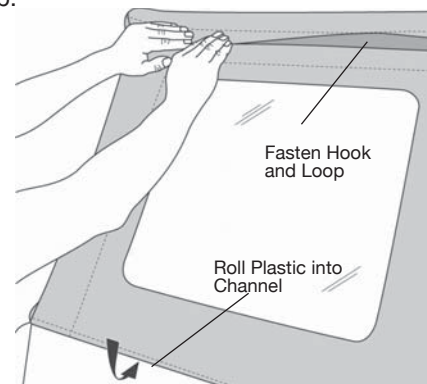

## Step Twenty-two

### INSTALL ELASTIC GARTERS

Snap the Elastic Garters to the snaps on the Rear Bow above the rear window opening.

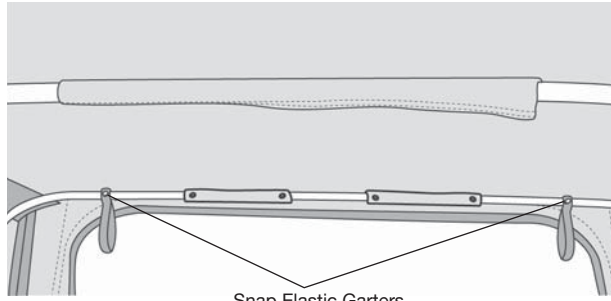

Snap Elastic Garters to Rear Bow

## Step Twenty-three

### INSTALL TAILGATE BAR ON REAR WINDOW

Remove the Rear Window from the box and lay it flat with the backing side up. Locate the Tailgate Bar set aside in Step One. The bar has a "C" shaped channel, when viewed from the end. Orient the bar with the round seal down and slide the "C" channel on the retainer onto the tubed strip sewn to the backing side of the Rear Window.

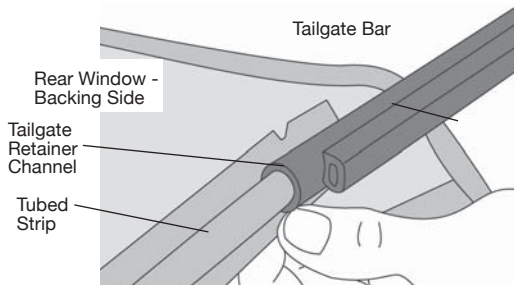

## Step Twenty-four

### INSTALL TAILGATE BAR ON VEHICLE

Insert the Tailgate Bar into the mounts on each side of the tailgate opening with the vinyl side of the Rear Window toward the outside of the vehicle.

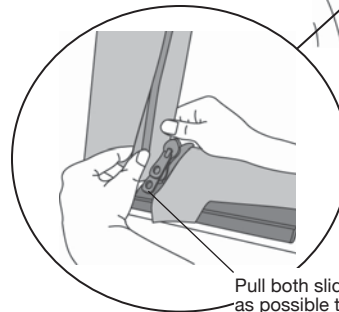
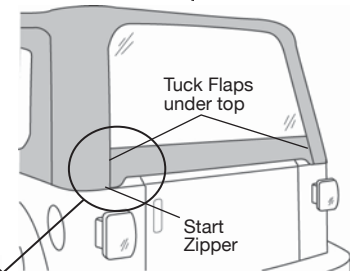
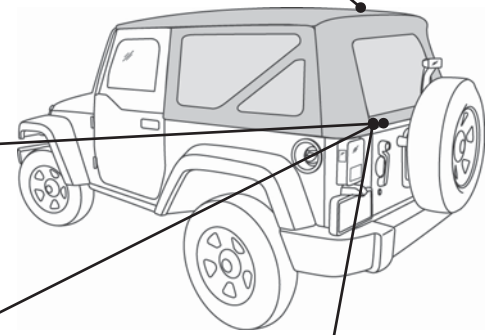
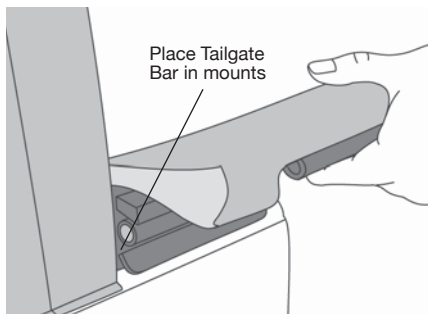

## Step Twenty-five

### SECURE REAR WINDOW ZIPPERS

To start the zipper, pull the two sliders as far down as possible on the driver's side of the window in order to catch the sliders to the pin.

Once the zipper is caught, start the top slider 1/2". Then hold up the top of the window with one hand and close the zipper with the other. The zipper is sandwiched between layers of fabric in the corners so be careful not to catch extra fabric in the zipper. Close the zipper.

Make sure that the Tailgate Bar is centered and is securely in the mounts. Then tuck the flaps on the Rear Window under the top fabric.

## Step Twenty-six

### To FOLD THE TOP DOWN

#### REMOVE QUARTER PANELS AND REAR WINDOW

Remove the Quarter Panels and the Rear Window. To remove the Quarter Windows, unzip the rear and top zippers. Release the plastic strip from the retainer. Release the Hook and Loop Fasteners from around the Vertical Retainer.

To roll up the Rear Window, remove the Tailgate Bar and open the zippers on each side of the window to the top. Start at the bottom and roll the window to the inside. Avoid wrinkles in the fabric and window. Secure it in place with the elastic garters inside of the top.



### WARNING

When operating the vehicle without the Quarter Windows, the Rear Window should be rolled up and secured with the elastic garters for proper ventilation.

## Step Twenty-seven

### To FOLD THE TOP DOWN

#### COLLAPSE TOP

Release the front of the top from the windshield. Raise the front of the deck and collapse the rear bows, tucking the two plastic strips above the door openings and the stay pad on the rear bow inside of the bows, Wrap the fabric around the bows, then tuck the rear legs of the top under the bows.

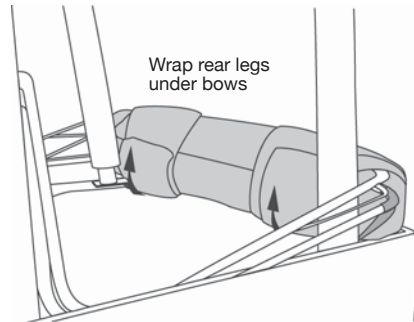
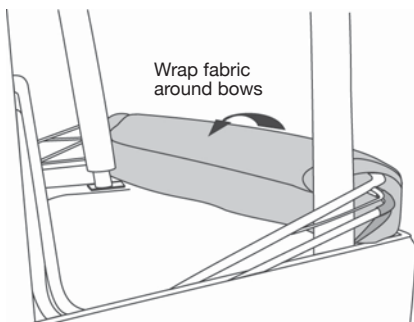
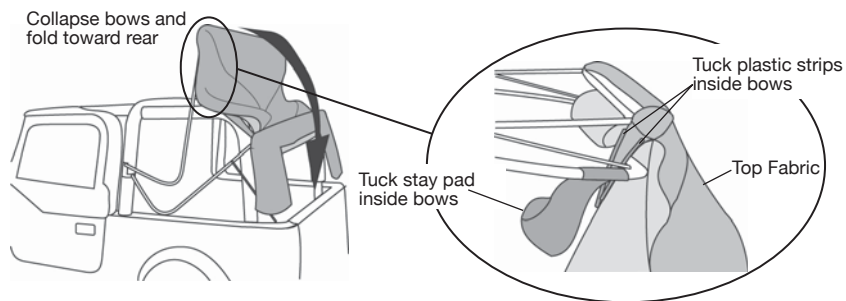



## Care and Maintenance of your New Top

Your top is made of the finest materials available. To keep it looking new and for the maximum possible wear, it will need periodic cleaning and maintenance.

**Washing:** The fabric should be washed often using soap, warm water and a soft bristle brush. Rinse with clear water to remove all traces of soap.

**Zippers:** Keeping the zipper cleaned and lubricated with a silicone lubricant will help prevent damage and keep the zippers in a smooth working condition. If a zipper opens behind the slider, the slider may have been spread apart. This problem can usually be repaired by using an ordinary pair of pliers to bring the sides back into parallel. Return slider to the end of the zipper in the normal Open position. Squeeze lightly at first and test the zipper. If the zipper continues to remain open squeeze more firmly with the pliers and try the zipper again. Repeat this procedure until the zipper operates correctly.

**Water:** In the event of seeping through the seams, 3M Scotchgard® may be applied on the inside of the seams to stop the seepage. Rips in the fabric may be repaired with Bondex® iron on patches. Iron the patches to the inside of the top, carefully following the Bondex® instructions.

**Snaps:** Keep snaps cleaned and lubricated with silicone to help prevent snaps from sticking to the studs. If a snap does become stuck to a stud, use a screwdriver and GENTLY pry apart to prevent permanent damage to the snap or the top fabric.

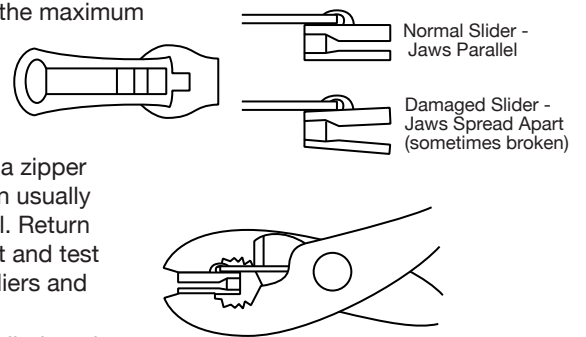

---

## LIMITED WARRANTY

We warrant our product to be free from defects in material and workmanship, for terms specified below, provided there has been normal use and proper maintenance. This warranty applies to the original purchaser only. All remedies under this warranty are limited to the repair or replacement of any item or items found by the factory to be defective within the time period specified.

If you have a warranty claim, first you must call our factory at the number below for instructions. You must retain proof of purchase and submit a copy with any items returned for warranty work. Upon completion of warranty work, if any, we will return the repaired or replaced item or items to you freight prepaid. Damage to our products caused by accidents, fire, vandalism, negligence, misinstallation, misuse, Acts of God, or by defective parts not manufactured by us, is not covered under this warranty.

THE WARRANTY TIME PERIOD IS AS FOLLOWS: ALL "GOODS" MANUFACTURED BY OUR COMPANY: ONE YEAR FROM DATE OF PURCHASE.

ANY IMPLIED WARRANTIES OF MERCHANTABILITY AND/OR FITNESS FOR A PARTICULAR PURPOSE CREATED HEREBY ARE LIMITED IN DURATION TO THE SAME DURATION AND SCOPE AS THE EXPRESS WRITTEN WARRANTY. OUR COMPANY SHALL NOT BE LIABLE FOR ANY INCIDENTAL OR CONSEQUENTIAL DAMAGE.

Some states do not allow limitations on how long an implied warranty lasts, or the exclusion or limitation of incidental or consequential damages, so the above limitations or exclusions may not apply to you.

This warranty gives you specific legal rights, and you may also have other rights which vary from state to state.

For further information, please contact:

Customer Service  
877-638-9509

All or a portion of this product may have been made in China.